

## Industrial Automation Headquarters

**Delta Electronics, Inc.**  
 Taoyuan Technology Center  
 No.18, Xinglong Rd., Taoyuan City,  
 Taoyuan County 33068, Taiwan  
 TEL: 886-3-362-6301 / FAX: 886-3-371-6301

## Asia

**Delta Electronics (Jiangsu) Ltd.**  
 Wujiang Plant 3  
 1688 Jiangxing East Road,  
 Wujiang Economic Development Zone  
 Wujiang City, Jiang Su Province, P.R.C. 215200  
 TEL: 86-512-6340-3008 / FAX: 86-769-6340-7290

**Delta Greentech (China) Co., Ltd.**  
 238 Min-Xia Road, Pudong District,  
 ShangHai, P.R.C. 201209  
 TEL: 86-21-58635678 / FAX: 86-21-58630003

**Delta Electronics (Japan), Inc.**  
 Tokyo Office  
 2-1-14 Minato-ku Shibadaimon,  
 Tokyo 105-0012, Japan  
 TEL: 81-3-5733-1111 / FAX: 81-3-5733-1211

**Delta Electronics (Korea), Inc.**  
 1511, Byucksan Digital Valley 6-cha, Gasan-dong,  
 Geumcheon-gu, Seoul, Korea, 153-704  
 TEL: 82-2-515-5303 / FAX: 82-2-515-5302

**Delta Electronics Int'l (S) Pte Ltd.**  
 4 Kaki Bukit Ave 1, #05-05, Singapore 417939  
 TEL: 65-6747-5155 / FAX: 65-6744-9228

**Delta Electronics (India) Pvt. Ltd.**  
 Plot No 43 Sector 35, HSIIDC  
 Gurgaon, PIN 122001, Haryana, India  
 TEL : 91-124-4874900 / FAX : 91-124-4874945

## Americas

**Delta Products Corporation (USA)**  
 Raleigh Office  
 P.O. Box 12173, 5101 Davis Drive,  
 Research Triangle Park, NC 27709, U.S.A.  
 TEL: 1-919-767-3800 / FAX: 1-919-767-8080

**Delta Greentech (Brasil) S.A.**  
 Sao Paulo Office  
 Rua Itapeva, 26 - 3° andar Edificio Itapeva One-Bela Vista  
 01332-000-São Paulo-SP-Brazil  
 TEL: 55 11 3568-3855 / FAX: 55 11 3568-3865

## Europe

**Deltronics (The Netherlands) B.V.**  
 Eindhoven Office  
 De Witbogt 20, 5652 AG Eindhoven, The Netherlands  
 TEL : +31-40-2592850 / FAX : +31-40-2592851

DVP-0001820-01

\*We reserve the right to change the information in this manual without prior notice.

2014-11-14

[www.deltaww.com](http://www.deltaww.com)



# DVP10RC-E2 Resolver Input Module Operation Manual

# DVP10RC-E2 Resolver Input Module

## Operation Manual

### Table of Contents

#### Chapter 1 Introduction

1.1	Specifications .....	1-2
1.2	Dimensions .....	1-3
1.3	Profile .....	1-3
1.4	Arrangement of the I/O Terminals .....	1-4
1.5	Wiring I/O Terminals .....	1-4
1.6	LED Indicators and Troubleshooting.....	1-4

#### Chapter 2 Control Registers

2.1	Table of Control Registers .....	2-2
2.2	Functions .....	2-6
2.2.1	Adjusting an Angle .....	2-6
2.2.2	Rotational Speed.....	2-7
2.2.3	Counting the Number of Revolutions .....	2-7
2.2.4	Forward/Backward Rotation .....	2-8
2.2.5	Cam Output .....	2-8
2.2.6	Using Y0 and Y1 as High-speed Output Terminals .....	2-9
2.2.7	Controlling a Brake by Means of Y10/Y11 .....	2-10
2.2.8	Automatically Bringing out a Gliding Angle List .....	2-12
2.2.9	Offset Angle Percentage .....	2-13
2.3	Descriptions of D9900~D9999 .....	2-14





# Chapter 1 Introduction

## Table of Contents

1.1	Specifications .....	1-2
1.2	Dimensions .....	1-3
1.3	Profile .....	1-3
1.4	Arrangement of the I/O Terminals .....	1-4
1.5	Wiring I/O Terminals .....	1-4
1.6	LED Indicators and Troubleshooting .....	1-4

1

Thanks for using the resolver input module DVP10RC-E2. To ensure that the product is correctly installed and operated, users need to read the operation manual carefully before they use DVP10RC-E2.

- ✓ The operation manual provides functional specifications, and introduces installation, basic operation and setting, and the usage of DVP10RC-E2.
- ✓ DVP10RC-E2 is an OPEN-TYPE device. It should be installed in a control cabinet free of airborne dust, humidity, electric shock and vibration. To prevent non-maintenance staff from operating DVP10RC-E2, or to prevent an accident from damaging DVP10RC-E2, the control cabinet in which DVP10RC-E2 is installed should be equipped with a safeguard. For example, the control cabinet in which DVP10RC-E2 is installed can be unlocked with a special tool or key. DO NOT touch any terminal when DVP10RC-E2 is powered up.
- ✓ In order to prevent the product from being damaged, or prevent staff from being hurt, users need to read the operation manual carefully, and follow the instructions in the manual.

## 1.1 Specifications

<b>DVP10RC-E2</b>		
<b>Supply voltage</b>	24 V DC (20.4 V DC~28.8 V DC) (-15%~+20%)	
<b>Maximum rated power consumption</b>	1 W Supplied by an external power source	
<b>Connection</b>	European standard removable terminal block (Pin pitch: 5 mm)	
<b>Operating/Storage environment</b>	Operating environment: 0°C~55°C (temperature); 5~95% (humidity); pollution degree 2 Storage environment: -25°C~70°C (temperature); 5~95% (humidity)	
<b>Vibration/Shock resistance</b>	International standards: IEC 61131-2, IEC 68-2-6 (TEST Fc)/IEC 61131-2 & IEC 68-2-27 (TEST Ea)	
<b>Connecting to a DVP series PLC</b>	The modules connected to a PLC are numbered from 0 to 7 according to their distances from the PLC. Eight modules at most can be connected to a PLC, and do not occupy any digital inputs/outputs.	
<b>Output terminals</b>	There are two synchronous brake output terminals (Y10 and Y11), two high-speed comparison output terminals (Y0 and Y1), and six general control output terminals (Y2~Y7).	
<b>Resolver</b>		
<b>Output terminals</b>	<b>R1, R2</b>	Resolver power outputs; 7 Vms, 10 kHz
<b>Input terminals</b>	<b>S1, S2, S3, S4</b>	Resolver signal inputs; 3.5±0.175 Vrms, 10 kHz
<b>Resolution</b>	12 bits (0~4095)	
<b>Distance</b>	50 meters	
<b>Rotational speed</b>	500 rpm	
<b>Disconnection detection</b>	Disconnection detection is supported.	

## 1.2 Dimensions

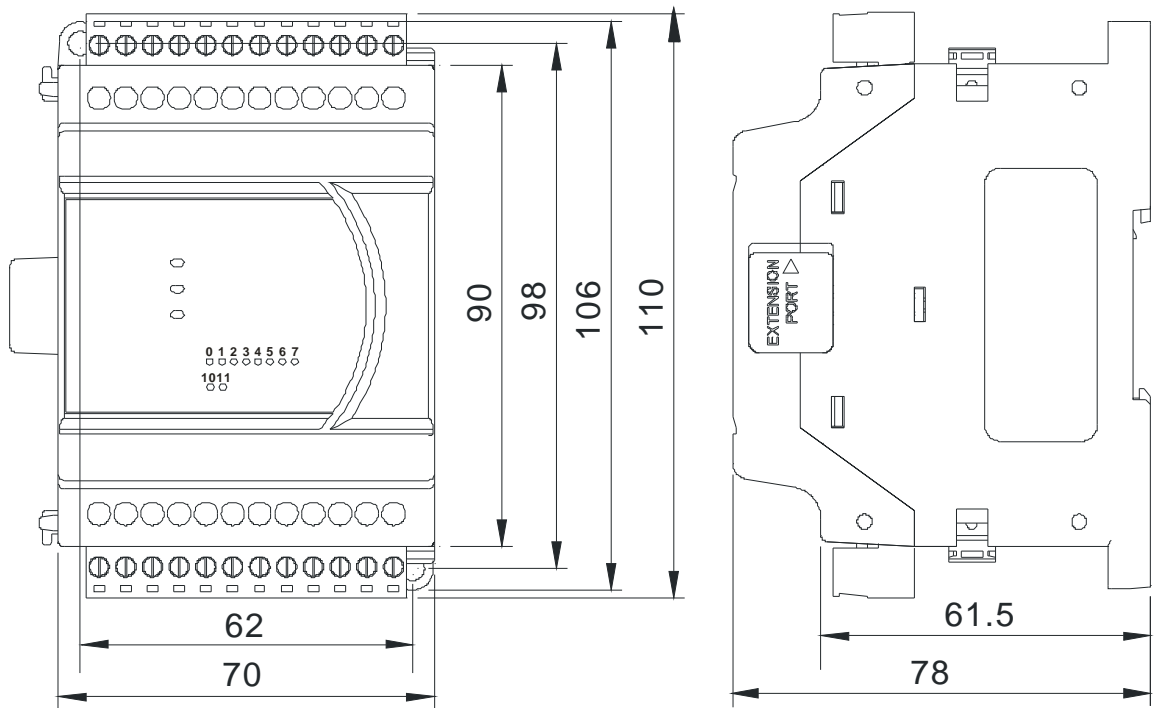

Unit:mm

## 1.3 Profile

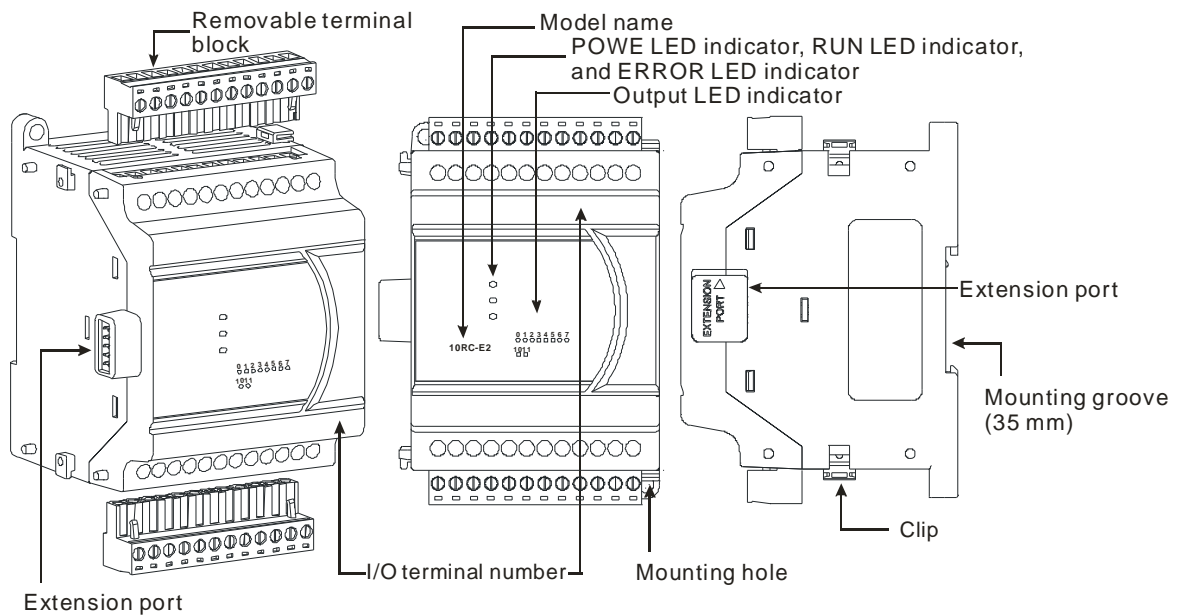

1

### 1.4 Arrangement of the I/O Terminals

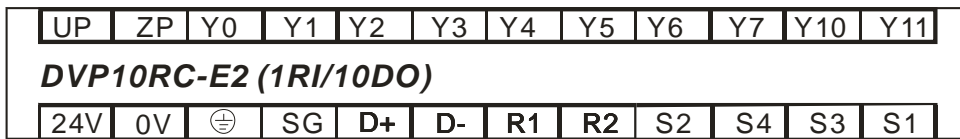

### 1.5 Wiring I/O Terminals

- Wiring input terminals

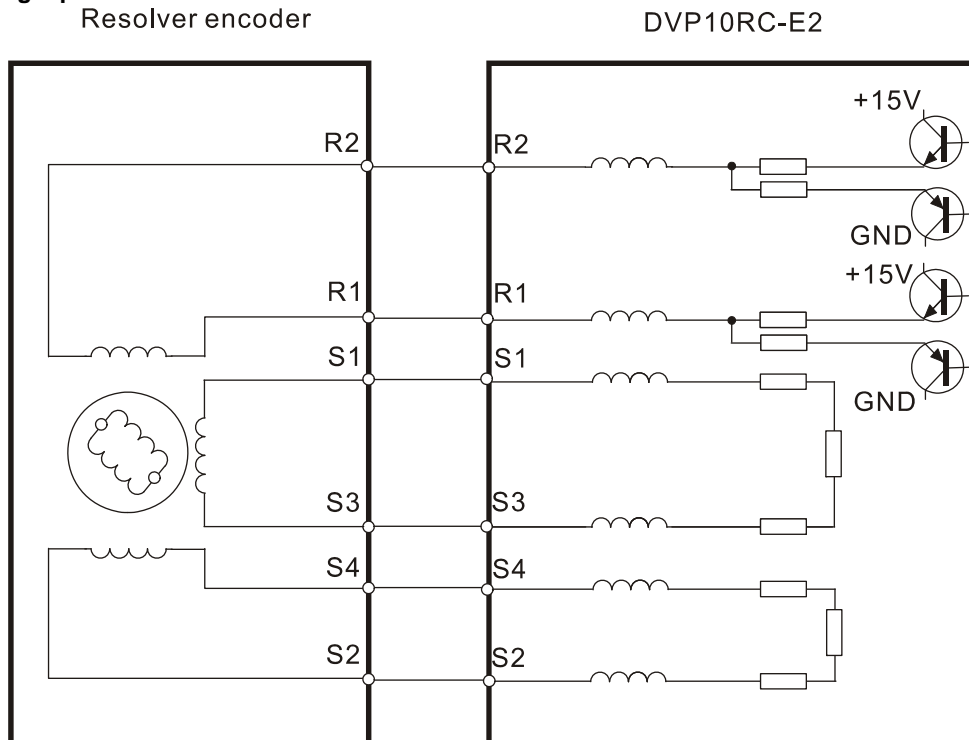

- Wiring output terminals

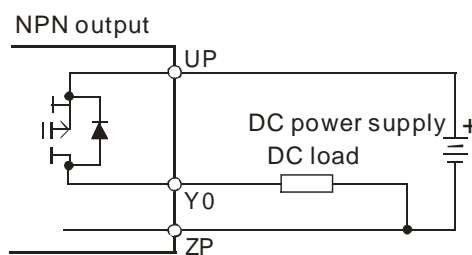

### 1.6 LED Indicators and Troubleshooting

- LED indicators

LED indicator	Color	Description
POWER	Green	The POWER LED indicator indicates whether there is power supplied to the CPU board.
RUN	Green	The RUN LED indicator indicates whether the module is running.
ERROR	Red	The ERROR LED indicator indicates whether an error occurs.
Y0~Y7, and Y10~Y11	Red	An output LED indicator indicates whether there is an output signal.

## ● RUN LED indicator and ERROR LED indicator

RUN LED indicator	ERROR LED indicator	Description	Remedy
OFF	ON	<ol style="list-style-type: none"><li>1. The external power supplied to the module is abnormal.</li><li>2. An input signal received by the resolver connected is abnormal. (The resolver used is disconnected.)</li><li>3. A rotational speed exceeds the range which can be resolved by the resolver connected.</li></ol>	Check external wiring.
ON	Blinking	Abnormal start	Check whether the resolver connected rotates.
ON	OFF	The module is in a normal state.	No remedy is needed.

1



**MEMO**



# 2

## Chapter 2 Control Registers

### Table of Contents

2.1	Table of Control Registers.....	2-2
2.2	Functions.....	2-6
2.2.1	Adjusting an Angle.....	2-6
2.2.2	Rotational Speed.....	2-7
2.2.3	Counting the Number of Revolutions.....	2-7
2.2.4	Forward/Backward Rotation.....	2-8
2.2.5	Cam Output.....	2-8
2.2.6	Using Y0 and Y1 as High-speed Output Terminals.....	2-9
2.2.7	Controlling a Brake by Means of Y10/Y11.....	2-10
2.2.8	Automatically Bringing out a Gliding Angle List.....	2-12
2.2.9	Offset Angle Percentage.....	2-13
2.3	Descriptions of D9900~D9999.....	2-14

## 2.1 Table of Control Registers

2

CR#	Attribute		Communication address	Name	Description	Default value
#0	R	O	H1000	Model code	The model code of a resolver input module is defined by the module's system. DVP10RC-E2's model code=H'0026	--
#1	R	O	H1001	Firmware version	Hexadecimal value Current firmware version	--
#3	R	X	H1003	State flag	Current state of DVP10RC-E2	--
#4	R	X	H1004	Digital value of a resolver	K0~K4095	--
#5	R	X	H1005	Angle of a resolver	K0~K3599 (Unit: 0.1 degrees)	--
#6	R	X	H1006	Angle of rotation	K0~K3599 (Unit: 0.1 degrees)	--
#7	R	X	H1007	Rotational speed	Unit: rpm	--
#8	R	X	H1008	Number of revolutions	K0~K32767 (Unit: Revolution) If the value in CR#8 overflows, it will become zero.	K0
#9	R	X	H1009	States of the output terminals on DVP10RC-E2 (1: ON; 0: OFF)	Bit 0~bit 7: Y0~Y7 Bit 8: Y10 Bit 9: Y11 Bit 10~bit 15: Reserved	--
#10	R	O	H100A	Angular offset	K-3599~K3599 (Unit: 0.1 degrees)	K0
#11	R/W	O	H100B	Target value for the adjustment of an angle	K0~K3599 (Unit: 0.1 degrees)	K0
#13	R/W	X	H100D	Mode of controlling a brake by means of Y10 and Y11	K0: No action K1: Inching mode K2: Continuous mode K3: Safe/Single mode	K0
#14	R/W	O	H100E	Station period	K0~K1000 (Unit: 1 ms) Range: 1 ms~1000 ms K0: A system automatically brings out a station period according to a rotational speed.	K20
#15	R/W	O	H100F	Station range	K1~K100 (Unit: 0.1 degrees)	K10
#16	R/W	O	H1010	Forward/Backward rotation	K0=Forward rotation K1=Backward rotation	K0
#17	R/W	X	H1011	Control command	K0: None K1: Stopping applying a brake (Y10 and Y11 are ON.) K2: Starting to apply a brake (Y10 and Y11 are OFF.) K3: Clearing the number of revolutions K4: Automatically bringing out a gliding angle list K5: Clearing an offset angle list K6: Clearing a gliding angle list K7: Adjusting an angle	K0
#20	R/W	O	H1014	Mode of communication	K0: MODBUS mode K1: DVP-F6SEG's mode of communication	K1
#21	R/W	O	H1015	Communication station address	RS-485 communication address (1~254)	K1

CR#	Attribute		Communication address	Name	Description	Default value
#22	R/W	O	H1016	Communication format	<p>There are six types of communication rates (4,800~115,200 bps)</p> <p>b0: 4,800 bps  b1: 9,600 bps (Default value)  b2: 19,200 bps  b3: 38,400 bps  b4: 57,600 bps  b5: 115,200 bps  b6~b13: Reserved  b14: The high eight bits in a CRC checksum is interchanged with the low eight bits in the CRC checksum. (Only effective in an RTU mode)  b15=0: ASCII mode  b15=1: RTU mode</p> <p>ASCII mode: 7 bits, even parity bit, 1 stop bit (7, E, 1)  RTU mode: 8 bits, even parity bit, 1 stop bit (8, E, 1)  Default value: H'0002.</p>	See the description of CR#22.
#23	R/W	X	H1017	Angle of advance	K0~K3599 (Unit: 0.1 degrees)	K1800
#24	R/W	X	H1018	Angle of departure	K0~K3599 (Unit: 0.1 degrees)	K2500
#25	R/W	O	H1019	Way in which Y0 and Y1 operate	0: Angle comparison output terminals 1: High-speed output terminals	K0
#26	R/W	O	H101A	Start angle to which Y0 corresponds	K0~K3599 (Unit: 0.1 degrees)	K0
#27	R/W	O	H101B	End angle to which Y0 corresponds	K0~K3599 (Unit: 0.1 degrees)	K0
#28	R/W	O	H101C	Start angle to which Y1 corresponds	K0~K3599 (Unit: 0.1 degrees)	K0
#29	R/W	O	H101D	End angle to which Y1 corresponds	K0~K3599 (Unit: 0.1 degrees)	K0
#30	R/W	O	H101E	Start angle to which Y2 corresponds	K0~K3599 (Unit: 0.1 degrees)	K0
#31	R/W	O	H101F	End angle to which Y2 corresponds	K0~K3599 (Unit: 0.1 degrees)	K0
#32	R/W	O	H1020	Start angle to which Y3 corresponds	K0~K3599 (Unit: 0.1 degrees)	K0
#33	R/W	O	H1021	End angle to which Y3 corresponds	K0~K3599 (Unit: 0.1 degrees)	K0
#34	R/W	O	H1022	Start angle to which Y4 corresponds	K0~K3599 (Unit: 0.1 degrees)	K0
#35	R/W	O	H1023	End angle to which Y4 corresponds	K0~K3599 (Unit: 0.1 degrees)	K0
#36	R/W	O	H1024	Start angle to which Y5 corresponds	K0~K3599 (Unit: 0.1 degrees)	K0
#37	R/W	O	H1025	End angle to which Y5 corresponds	K0~K3599 (Unit: 0.1 degrees)	K0
#38	R/W	O	H1026	Start angle to which Y6 corresponds	K0~K3599 (Unit: 0.1 degrees)	K0
#39	R/W	O	H1027	End angle to which Y6 corresponds	K0~K3599 (Unit: 0.1 degrees)	K0
#40	R/W	O	H1028	Start angle to which Y7 corresponds	K0~K3599 (Unit: 0.1 degrees)	K0

CR#	Attribute		Communication address	Name	Description	Default value
#41	R/W	O	H1029	End angle to which Y7 corresponds	K0~K3599 (Unit: 0.1 degrees)	K0
#42	R/W	O	H102A	Minimum rotational speed	Range: 1~200 (Unit: rpm)	K0
#43	R/W	O	H102B	Gliding angle corresponding to a minimum rotational speed	K0~K3599 (Unit: 0.1 degrees)	K0
#44	R/W	O	H102C	Maximum rotational speed	Range: 1~200 (Unit: rpm)	K0
#45	R/W	O	H102D	Gliding angle corresponding to a maximum rotational speed	K0~K3599 (Unit: 0.1 degrees)	K0
#48	R/W	O	H102E	Offset angle percentage	K0 = 0% (No offset) K1 = 25% (Offset) K2 = 50% (Offset) K3 = 100% (Offset)	K2
#49	R/W	O	H1031	Stop angle	K0~K3599 (Unit: 0.1 degrees)	K0
#50	R/W	O	H1032	Gliding angle (10 rpm)	K0~K3599 (Unit: 0.1 degrees)	K0
#51	R/W	O	H1033	Gliding angle (20 rpm)	K0~K3599 (Unit: 0.1 degrees)	K0
#52	R/W	O	H1034	Gliding angle (30 rpm)	K0~K3599 (Unit: 0.1 degrees)	K0
#53	R/W	O	H1034	Gliding angle (40 rpm)	K0~K3599 (Unit: 0.1 degrees)	K0
#54	R/W	O	H1035	Gliding angle (50 rpm)	K0~K3599 (Unit: 0.1 degrees)	K0
#55	R/W	O	H1036	Gliding angle (60 rpm)	K0~K3599 (Unit: 0.1 degrees)	K0
#56	R/W	O	H1037	Gliding angle (70rpm)	K0~K3599 (Unit: 0.1 degrees)	K0
#57	R/W	O	H1038	Gliding angle (80 rpm)	K0~K3599 (Unit: 0.1 degrees)	K0
#58	R/W	O	H1039	Gliding angle (90 rpm)	K0~K3599 (Unit: 0.1 degrees)	K0
#59	R/W	O	H103A	Gliding angle (100 rpm)	K0~K3599 (Unit: 0.1 degrees)	K0
#60	R/W	O	H103B	Gliding angle of braking (110 rpm)	K0~K3599 (Unit: 0.1 degrees)	K0
#61	R/W	O	H103C	Gliding angle (120 rpm)	K0~K3599 (Unit: 0.1 degrees)	K0
#62	R/W	O	H103D	Gliding angle (130 rpm)	K0~K3599 (Unit: 0.1 degrees)	K0
#63	R/W	O	H103E	Gliding angle (140 rpm)	K0~K3599 (Unit: 0.1 degrees)	K0
#64	R/W	O	H103F	Gliding angle (150 rpm)	K0~K3599 (Unit: 0.1 degrees)	K0
#65	R/W	O	H1040	Gliding angle (160 rpm)	K0~K3599 (Unit: 0.1 degrees)	K0
#66	R/W	O	H1041	Gliding angle (170 rpm)	K0~K3599 (Unit: 0.1 degrees)	K0
#67	R/W	O	H1042	Gliding angle (180 rpm)	K0~K3599 (Unit: 0.1 degrees)	K0
#68	R/W	O	H1043	Gliding angle (190 rpm)	K0~K3599 (Unit: 0.1 degrees)	K0
#69	R/W	O	H1044	Gliding angle (200 rpm)	K0~K3599 (Unit: 0.1 degrees)	K0
#70	R/W	O	H1046	Rotational speed of an offset angle	K1~k200 (Unit: rpm)	K0
#71	R/W	O	H1047	Offset angle	K0~K3599 (Unit: 0.1 degrees)	K0

CR#	Attribute		Communication address	Name	Description	Default value
#100~ #119	R/W	O	H1064~ H1077	Number of revolutions set for Y0	K0~K32767	K0
#120~ #139	R/W	O	H1078~ H108B	Number of revolutions set for Y1	K0~K32767	K0
#140~ #159	R/W	O	H108C~ H109F	Start angle corresponding to the number of revolutions set for Y0	K0~K3599 (Unit: 0.1 degrees)	K0
#160~ #179	R/W	O	H1080~ H10B3	Start angle corresponding to the number of revolutions set for Y1	K0~K3599 (Unit: 0.1 degrees)	K0
#180~ #199	R/W	O	H10B4~ H10C7	End angle corresponding to the number of revolutions set for Y0	K0~K3599 (Unit: 0.1 degrees)	K0
#200~ #219	R/W	O	H10C8~ H10DB	End angle corresponding to the number of revolutions set for Y1	K0~K3599 (Unit: 0.1 degrees)	K0
Symbols: O: The register is a retentive register. X: The register is not a retentive register. R: User can read the data in the control register by means of the instruction FROM, or RS-485 communication. (Only 03 (reading) is supported.) W: Users can write data to the control register by means of the instruction TO.						

## ※ CR#3: State flag

Bit	Description	1	0
Bit 0	External power supply flag	Abnormal	Normal
Bit 1	Abnormal start	Abnormal	Normal
Bit 2	An input signal received by the resolver connected is abnormal. (The resolver used is disconnected.)	Abnormal	Normal
Bit 3	A rotational speed exceeds the range which can be resolved by the resolver connected.	Abnormal	Normal
Bit 4	Station judgment flag	Static	Not static
Bit 5~bit 15	Reserved	--	--

2

## 2.2 Functions

### 2.2.1 Adjusting an Angle

Making the angle which is set the current angle: After DVP10RC-E2 reads the absolute angle of a resolver, the absolute angle will be displayed in CR#5. However, after a system is created, users want to change the current angle to a certain angle.

2

- Example: Changing an angle to 90°  
 After a system is created, the angle displayed is CR#6 is 45° (K450). Users want to change the angle to 90° (K900).  
 Step 1: Write 90° (K900) to CR#11.  
 Step 2: Write K7 to CR#17.

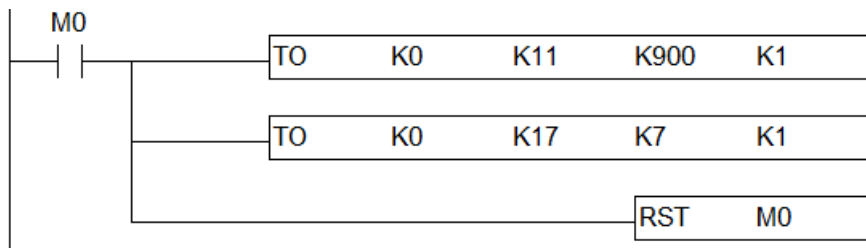

After the adjustment of the angle is complete, an angular offset will be displayed in CR#10.

- Related control registers

CR#	Attribute	Communication address	Name	Description	Default value
#5	R	H1005	Angle of a resolver	Absolute angle of a resolver K0~K3599 (Unit: 0.1 degrees)	--
#6	R	H1006	Angle of rotation	Angle of rotation after adjustment K0~K3599 (Unit: 0.1 degrees)	--
#10	R/W	H100A	Angular offset	Difference between the angle of a resolver and the angle of rotation K-3599~K3599 (Unit: 0.1 degrees)	--
#11	R/W	H100B	Target value for the adjustment of an angle	K0~K3599 (Unit: 0.1 degrees)	K0
#17	R/W	H1011	Control command	K0: None K1: Stopping applying a brake (Y10 and Y11 are ON.) K2: Starting to apply a brake (Y10 and Y11 are OFF.) K3: Clearing the number of revolutions K4: Automatically bringing out a gliding angle list K5: Clearing an offset angle list K6: Clearing a gliding angle list K7: Adjusting an angle	K0

### 2.2.2 Rotational Speed

DVP10RC-E2 can detect the current rotational speed of a resolver. When the angle of the resolver is the angle of advance, DVP10RC-E2 starts to detect the rotational speed of the resolver. DVP10RC-E2 applies the brake connected when the angle of the resolver is the angle of departure. The current rotational speed of the resolver is displayed in CR#7.

- Related control registers

CR#	Attribute	Communication address	Name	Description	Default value
#7	R	H1007	Rotational speed	Unit: rpm	--
#23	R/W	H1017	Angle of advance	K0~K3599 (Unit: 0.1 degrees)	K1800
#24	R/W	H1018	Angle of departure	K0~K3599 (Unit: 0.1 degrees)	K2500

2

### 2.2.3 Counting the Number of Revolutions

After a resolver rotates forwards from 0 degrees to 360 degrees, the value in CR#8 will increase by 1. However, when the resolver rotates backwards, the number of revolutions displayed in CR#8 does not change. After the resolver makes one backward revolution, the value in CR#8 will not increase by 1, or decrease by 1. If the value in CR#8 overflows (exceeds K32767), it will become 0. If users want to clear the number of revolutions displayed in CR#8, they can write K3 to CR#17.

- Example: Clearing the number of revolutions

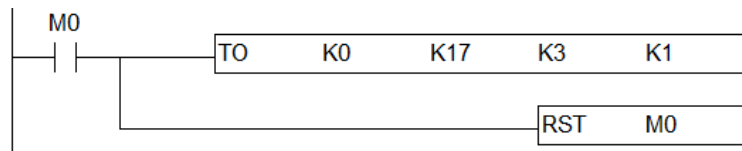

- Related control registers

CR#	Attribute	Communication address	Name	Description	Default value
#8	R	H1008	Number of revolutions	K0~K32767 (Unit: Revolution) If the value in CR#8 overflows, it will become zero.	K0
#17	R/W	H1011	Control command	K0: None K1: Stopping applying a brake (Y10 and Y11 are ON.) K2: Starting to apply a brake (Y10 and Y11 are OFF.) K3: Clearing the number of revolutions K4: Automatically bringing out a gliding angle list K5: Clearing an offset angle list K6: Clearing a gliding angle list K7: Adjusting an angle	K0



### 2.2.4 Forward/Backward Rotation

The system controlled by DVP10RC-E2 generally rotate forwards ( $0^\circ \rightarrow 90^\circ \rightarrow 180^\circ \rightarrow 270^\circ \rightarrow 0^\circ$ ). If it needs to rotate backwards, users have to write 1 to CR#16, otherwise problems may occur in other related control.

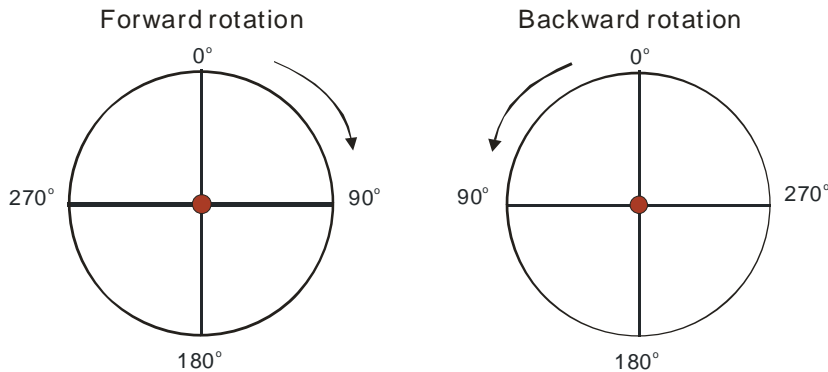

● Related control register

CR#	Attribute	Communication address	Name	Description	Default value
#16	R	H1010	Forward/Backward rotation	K0=Forward rotation K1=Backward rotation	K0

### 2.2.5 Cam Output

Users can set angle ranges for Y0~Y7. If the angle of a resolver is in the range of  $\theta_A \sim \theta_B$ , the output terminal corresponding to the angle range will be ON. If the angle of a resolver is not in the range of  $\theta_A \sim \theta_B$ , the output terminal corresponding to the range will be OFF. If the users want to use Y0 and Y1 as angle comparison output terminals, they have to write K0 to CR#25.

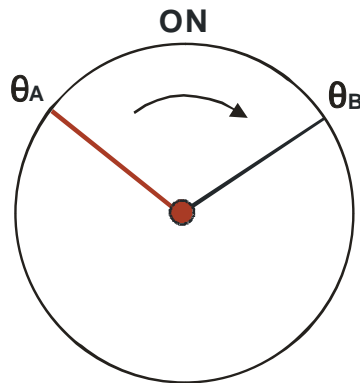

● Related control registers

CR#	Attribute	Communication address	Name	Description	Default value
#25	R/W	H1019	Way in which Y0 and Y1 operate	0: Angle comparison output terminals 1: High-speed output terminals	K0
#26	R/W	H101A	Start angle to which Y0 corresponds	K0~K3599 (Unit: 0.1 degrees)	K0
#27	R/W	H101B	End angle to which Y0 corresponds	K0~K3599 (Unit: 0.1 degrees)	K0
#28	R/W	H101C	Start angle to which Y1 corresponds	K0~K3599 (Unit: 0.1 degrees)	K0

CR#	Attribute	Communication address	Name	Description	Default value
#29	R/W	H101D	End angle to which Y1 corresponds	K0~K3599 (Unit: 0.1 degrees)	K0
#30	R/W	H101E	Start angle to which Y2 corresponds	K0~K3599 (Unit: 0.1 degrees)	K0
#31	R/W	H101F	End angle to which Y2 corresponds	K0~K3599 (Unit: 0.1 degrees)	K0
#32	R/W	H1020	Start angle to which Y3 corresponds	K0~K3599 (Unit: 0.1 degrees)	K0
#33	R/W	H1021	End angle to which Y3 corresponds	K0~K3599 (Unit: 0.1 degrees)	K0
#34	R/W	H1022	Start angle to which Y4 corresponds	K0~K3599 (Unit: 0.1 degrees)	K0
#35	R/W	H1023	End angle to which Y4 corresponds	K0~K3599 (Unit: 0.1 degrees)	K0
#36	R/W	H1024	Start angle to which Y5 corresponds	K0~K3599 (Unit: 0.1 degrees)	K0
#37	R/W	H1025	End angle to which Y5 corresponds	K0~K3599 (Unit: 0.1 degrees)	K0
#38	R/W	H1026	Start angle to which Y6 corresponds	K0~K3599 (Unit: 0.1 degrees)	K0
#39	R/W	H1027	End angle to which Y6 corresponds	K0~K3599 (Unit: 0.1 degrees)	K0
#40	R/W	H1028	Start angle to which Y7 corresponds	K0~K3599 (Unit: 0.1 degrees)	K0
#41	R/W	H1029	End angle to which Y7 corresponds	K0~K3599 (Unit: 0.1 degrees)	K0

- Example: Y2 is ON when the angle of a resolver is in the range of 90° to 180°.  
Step 1: Write K900 (90°) to CR#30.  
Step 2: Write K1800 (180°) to CR#31.

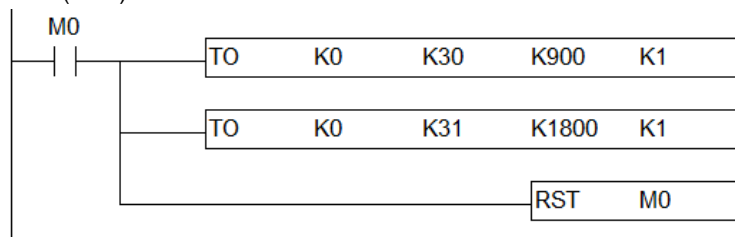

### 2.2.6 Using Y0 and Y1 as High-speed Output Terminals

After K0 is written to CR#25, Y0/Y1 will be ON if a resolver makes a certain number of revolutions and the angle of the resolver is in a certain range, and Y0/Y1 will be OFF if a resolver does make a certain number of revolutions and the angle of the resolver is not in a certain range.

Users can set twenty values in CR#100~CR#119 for Y0, and twenty values in CR#120~CR#139 for Y1.

- Related control registers

CR#	Attribute	Communication address	Name	Description	Default value
#25	R/W	H1019	Way in which Y0 and Y1 operate	0: Angle comparison output terminals 1: High-speed output terminals	K0
#100~ #119	R/W	H1064~ H1077	Number of revolutions set for Y0	K0~K32767	K0

2

CR#	Attribute	Communication address	Name	Description	Default value
#120~ #139	R/W	H1078~ H108B	Number of revolutions set for Y1	K0~K32767	K0
#140~ #219	R/W	H108C~ H10DB	Angle corresponding to the number of revolutions set for Y0/Y1	K0~K3599 (Unit: 0.1 degrees)	K0

- Example: If the resolver connected makes ten revolutions, and the angle of the resolver is in the range of 0° to 30°, Y0 will be ON.  
 If the resolver connected makes twenty revolutions, and the angle of the resolver is in the range of 30° to 60°, Y0 will be ON.  
 If the resolver connected makes forty revolutions, and the angle of the resolver is in the range of 60° to 90°, Y0 will be ON.  
 If the resolver connected makes forty-six revolutions, and the angle of the resolver is in the range of 90° to 160°, Y0 will be ON.

Number of revolutions set for Y0	Start angle corresponding to the number of revolutions set for Y0	End angle corresponding to the number of revolutions set for Y0
10	0°	30°
20	30°	60°
40	60°	90°
46	90°	160°

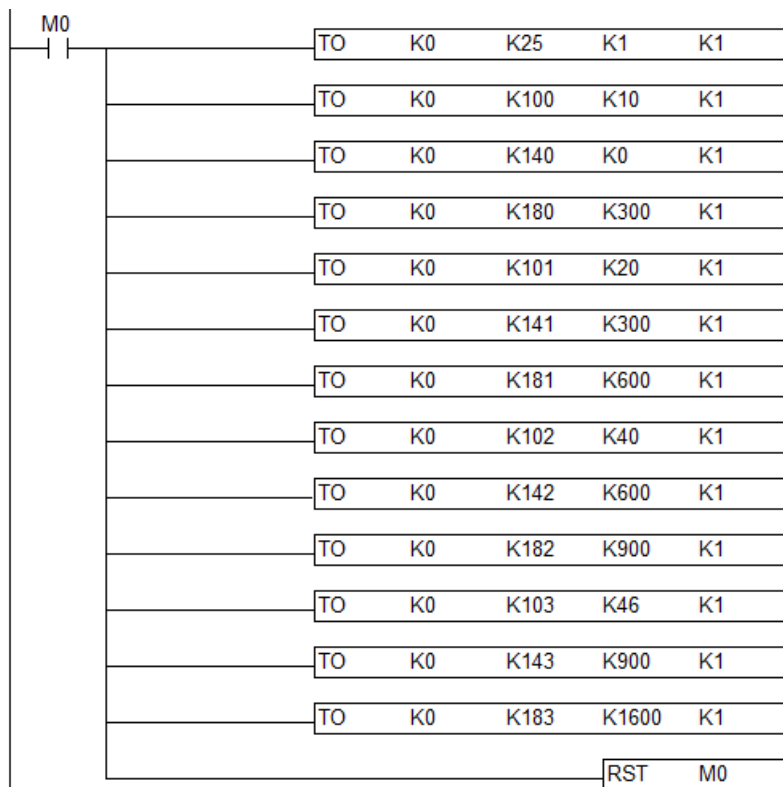

### 2.2.7 Controlling a Brake by Means of Y10/Y11

- Description: A brake is controlled by Y10 and Y11. Y10 and Y11 are ON or OFF simultaneously.

Output terminal	State	Control
Y10/Y11	OFF	Applying a brake
Y10/Y11	ON	Not applying a brake

- CR#13: Mode of controlling a brake by means of Y10 and Y11
  - No action (K0): The brake connected is applied. Y10 and Y11 are OFF continuously.
  - Inching mode (K1): Y10 and Y11 are ON continuously.
  - Continuous mode (K2): The brake connected is not applied initially. Y10 and Y11 are ON continuously. If K2 is written to CR#17, the brake connected will be applied (Y10 and Y11 will be OFF) according to the stop angle, the gliding angle, and the offset angle which are set by users after the angle of advance appears again. When the punching machine used stops, Y10 and Y11 are OFF. If the users write K1 to CR#17, the application of the brake connected will be stopped, Y10 and Y11 will be ON, and DVP10RC-E2 will wait for the next brake command.
  - Safe/Single mode (K3): Y10 and Y11 are ON initially. The brake connected will be applied automatically (Y10 and Y11 will be OFF) according to the stop angle, the gliding angle, and the offset angle which are set by users after the angle of advance appears again. When the punching machine used stops, Y10 and Y11 are OFF. If the users write K1 to CR#17, the application of the brake connected will be stopped, Y10 and Y11 will be ON, and the brake connected will be applied automatically after the angle of advance appears again.

CR#13	Mode of controlling a brake	States of Y10 and Y11
K0	No action	The brake connected is applied (Y10 and Y11 are OFF continuously).
K1	Inching mode	The brake connected is not applied (Y10 and Y11 are ON continuously).
K2	Continuous mode	Initial states: Y10 and Y11 are ON (The brake connected is not applied). Writing K2 to CR#17: The brake connected is applied (Y10 and Y11 are OFF) according to the stop angle, the gliding angle, and the offset angle which are set by users. Writing K1 to CR#17: The application of the brake connected is stopped (Y10 and Y11 are ON).
K3	Safe/Single mode	The brake connected is applied automatically (Y10 and Y11 are OFF) according to the stop angle, the gliding angle, and the offset angle which are set by users. Initial states: Y10 and Y11 are ON (The brake connected is not applied). Writing K1 to CR#17: The application of the brake connected is stopped (Y10 and Y11 are ON).

- Related control registers

CR#	Attribute	Communication address	Name	Description	Default value
#13	R/W	H100D	Mode of controlling a brake by means of Y10 and Y11	K0: No action K1: Inching mode K2: Continuous mode K3: Safe/Single mode	K0
#17	R/W	H1011	Control command	K0: None K1: Stopping applying a brake (Y10 and Y11 are ON.) K2: Starting to apply a brake (Y10 and Y11 are OFF.) K3: Clearing the number of revolutions K4: Automatically bringing out a gliding angle list K5: Clearing an offset angle list K6: Clearing a gliding angle list K7: Adjusting an angle	K0



CR#	Attribute	Communication address	Name	Description	Default value
#48	R/W	H102E	Offset angle percentage	K0 = 0% (No offset) K1 = 25% (Offset) K2 = 50% (Offset) K3 = 100% (Offset)	K2
#49	R/W	H1031	Stop angle	K0~K3599 (Unit: 0.1 degrees)	K0
#50~ #69	R/W	H1032 H1045	Gliding angle (10~200 rpm)	K0~K3599 (Unit: 0.1 degrees)	K0
#70	R/W	H1032	Rotational speed of an offset angle	K1~k200 (Unit: rpm)	K0
#71	R	H1033	Offset angle	K0~K3599 (Unit: 0.1 degrees)	K0

- Angle at which a brake is applied  
 Angel at which a brake is applied = Stop angle – Gliding angle – Offset angle  
 Example: The stop angle set in CR#49 is 100 degrees, the gliding angle set in CR#50 is 10 degrees, the gliding angle set in CR#51 is 20 degrees, and the offset angle set in CR71 is 0 degrees.
  - ◆ 10 rpm: The angle at which the brake connected is applied is 90 degrees.
  - ◆ 20 rpm: The angle at which the brake connected is applied is 80 degrees.
 Users have to set gliding angle, a stop angle, and an offset angle according to the system used.

### 2.2.8 Automatically Bringing out a Gliding Angle List

- Description:  
 If users want to control a brake, they have to write twenty gliding angles to CR#50~CR#69. However, twenty gliding angles can be brought into CR#50~CR#69 easily if the users follow the steps below.  
 Step 1: Write K6 to CR#17.  
 Step 2: The resolver connected completes one stroke at the rotational speed A. The rotational speed A is written to CR#42, and the difference between the angle at which the resolver connected needs to stop and the actual angle at which the resolver connected stops is written to CR#43.  
 Step 3: The resolver connected completes one stroke at the rotational speed B. The rotational speed B is written to CR#44, and the difference between the angle at which the resolver connected needs to stop and the actual angle at which the resolver connected stops is written to CR#45.  
 Step 4: Write K4 to CR#17.  
 After the users complete the steps above, they can read the gliding angles in CR#50~CR#69.

- Related control registers

CR#	Description
#17	Control command
#42	Rotational speed A
#43	Gliding angle corresponding to the rotational speed A
#44	Rotational speed B
#45	Gliding angle corresponding to the rotational speed B
#50~#69	Gliding angle (10~200 rpm)

- Example:  
 CR#42~CR#45 are used to bring a gliding angle list.  
 When the resolver connected rotates at 9 rpm, the gliding angle measured is 4.3 degrees.  
 When the resolver connected rotates at 157 rpm, the gliding angle measured is 84.3 degrees.  
 Writing K4 to CR#17: Automatically bringing out a gliding angle list

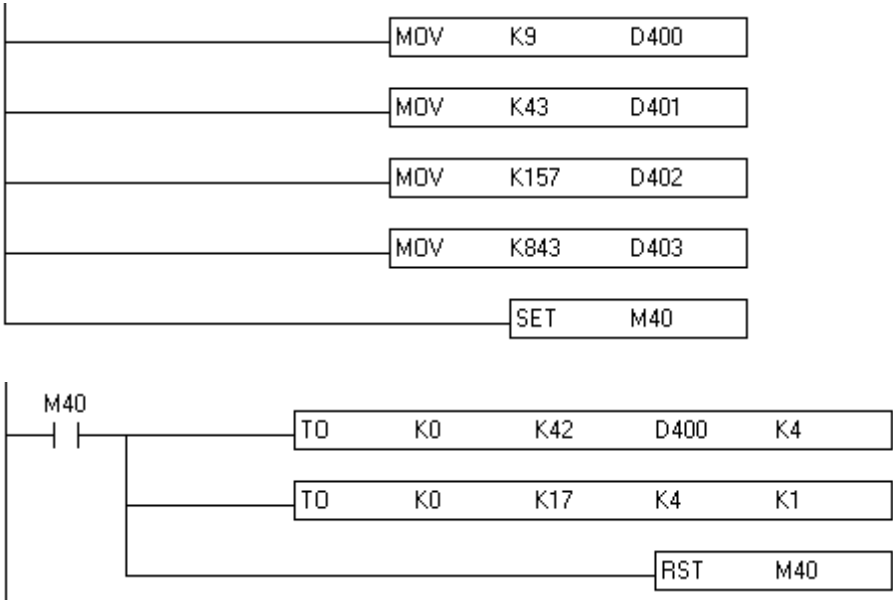

2.2.9 Offset Angle Percentage

CR#	Description
#48	Offset angle percentage

In addition to gliding angles, users can use an offset angle percentage. If the difference between the angle at which the resolver connected needs to stop and the actual angle at which the resolver connected stops is in the range of three degrees and thirty degrees when the resolve stops, the users can set an offset angle percentage.

- K0 = 0% (No offset)
- K1 = 25% (Offset)
- K2 = 50% (Offset)
- K3 = 100% (Offset)

Example: The offset angle percentage set in CR#48 is 50%. The resolver connected rotates at 50 rpm. When the resolver connected stops, the difference between the angle at which the resolver connected needs to stop and the actual angle at which the resolver connected stops is ten degrees. If the resolver connected rotates at 50 rpm again, and then stops, the difference between the angle at which the resolver connected needs to stop and the actual angle at which the resolver connected stops will be five degrees. There can be an offset only if the difference between the angle at which the resolver connected needs to stop and the actual angle at which the resolver connected stops is in the range of three degrees and thirty degrees.

## 2.3 Descriptions of D9900~D9999

If a DVP-ES2 series PLC is connected to special modules, the registers D9900~D9999 will be occupied. Users can use D9900~D9999 in a program by means of the instruction MOV.

If a DVP-ES2 series PLC is connected to DVP10RC-E2 resolver input modules, special data registers will be assigned to the DVP10RC-E2 resolver input modules in the way described below.

First module	Second module	Third module	Fourth module	Fifth module	Sixth module	Seventh module	Eighth module	Description
D1320	D1321	D1322	D1323	D1324	D1325	D1326	D1327	Model code of the special module which is connected
D9900	D9910	D9920	D9930	D9940	D9950	D9960	D9970	Angle of rotation
D9901	D9911	D9921	D9931	D9941	D9951	D9961	D9971	Rotational speed
D9902	D9912	D9922	D9932	D9942	D9952	D9962	D9972	Number of revolutions
D9903	D9913	D9923	D9933	D9943	D9953	D9963	D9973	States of the output terminals on the special module connected